



# MODEL 4004SP

INDUSTRIAL SPIRAL PIPE SUPPLY GRILLE  
GALV. STEEL & ALUMINUM - DOUBLE DEFLECTION

Project: \_\_\_\_\_  
 Tag: \_\_\_\_\_  
 Engineer: \_\_\_\_\_  
 Contractor: \_\_\_\_\_  
 Date: \_\_\_\_\_

## MODELS

**4004P:** Aluminum - Double Deflection - Vert. Front Blades

**4004SP:** Galv. Steel - Double Deflection - Vert. Front Blades

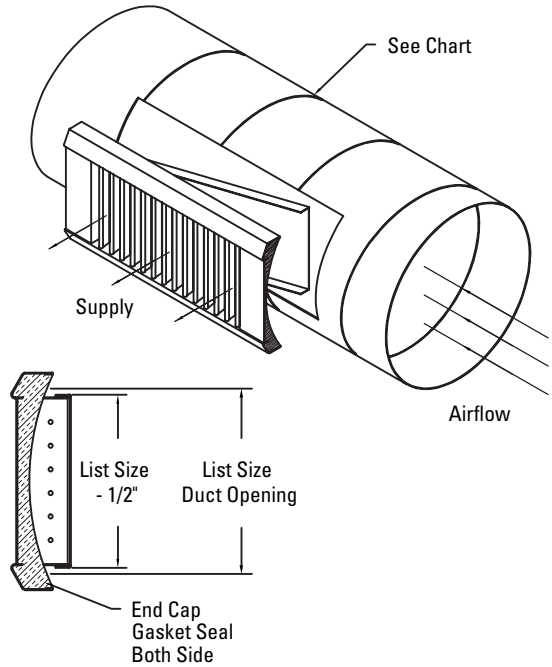
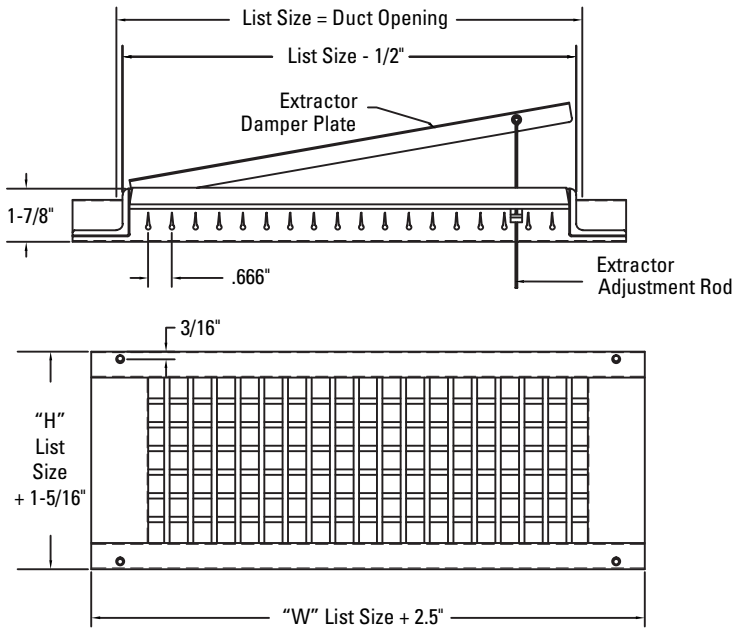

Available in Listed Sizes Only.

Height	Width														
	10"	12"	14"	16"	18"	20"	24"	30"	36"	38"	40"	42"	44"	46"	48"
	Minimum/Maximum Duct Diameter														
3"	6/24	6/24	6/24	6/24	6/24	6/24	6/24	6/24	6/24	6/24	6/24	6/24	6/24	6/24	6/24
4"	8/24	8/24	8/24	8/24	8/24	8/24	8/24	8/24	8/24	8/24	8/24	8/24	8/24	8/24	8/24
6"	12/24	12/24	12/24	12/24	12/24	12/24	12/24	12/24	12/24	12/24	12/24	12/24	12/24	12/24	12/24
8"	---	---	20/36	20/36	20/36	20/36	20/36	20/36	20/36	20/36	20/36	20/36	20/36	20/36	20/36
10"	---	---	---	---	30/48	30/48	30/48	30/48	30/48	30/48	30/48	30/48	30/48	30/48	30/48
12"	---	---	---	---	42/48	42/48	42/48	42/48	42/48	42/48	42/48	42/48	42/48	42/48	42/48

All Dimensions are in Inches.

1. Available Finishes	2. Available Accessories	3. Available Options	4. Construction Details
<b>Standard Finish (4004SP):</b> 24 Mill Finish Only (Galv. Steel) <b>Standard Finish (4004P):</b> 01 White			<ul style="list-style-type: none"> <li>Units Include Extractor with Wire Handle.</li> <li>Ends are Supplied with Foam Gasket to Seal Around Duct.</li> <li>Units are Surface Mount and Provided with Screw to Mount into Duct.</li> </ul>

As part of our continuous improvement program, we reserve the right to make further improvements without notice.

Submittal - 4004SP - 0220